

# FE510 CR# Series Orifice Meter Run Assembly With Carrier Ring

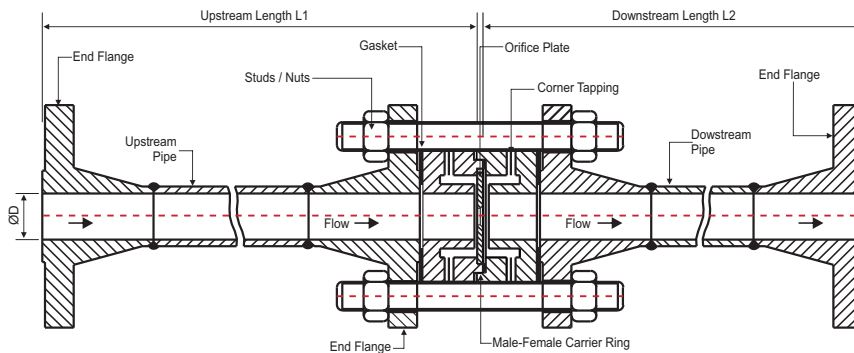

Orifice Meter Run assemblies can also be supplied with Male-Female type Carrier Rings which hold the plate. Corner tapplings are provided on Carrier Rings itself and are largely recommended for gas flow measurement with smaller line sizes viz; 15 NB to 50 NB where DP is very low.

The corner tapping are provided in the form of either annular grooves or slant drilling as per ISO 5167 / BS 1042 standard so that, the purging of the fluid into the tap is very effective and DP measurement is accurate.



|   |   |
|---|---|
| <b>Code</b> <b>Element Type/ Orifice Type</b><br>SEC   Square Edge Concentric<br>QE   Quadrant Edge<br>CE   Conical Entrance  | <b>Code</b> <b>Option</b><br>0   None<br>1   IBR Form IIIC<br>Other   See Table 7   |
| <b>Code</b> <b>Element Material</b><br>304   SS304<br>316   Ss316<br>316L   SS316L<br>Mo   Monel<br>Other   Please Specify  | <b>Code</b> <b>Gasket Material</b><br>G1   CAF<br>GP   PTFE / Taflon<br>G3   Ss304 + CAF<br>Other   Please Specify (Refer Table 5)  |
| <b>Code</b> <b>Element Thickness</b><br>W1   3.175 mm<br>W2   6.350 mm<br>W3   9.53 mm<br>W4   12.7 mm<br>XX   Other [please Specify]   | <b>Code</b> <b>Gasket Type</b><br>FR   Flat Ring<br>SP   Spiral Wound   |
| <b>Code</b> <b>NB/ Rating / Sch.</b><br>XX   Please Define (eg: 1"300# Sch.80)  | <b>Code</b> <b>Studs / Nuts Material</b><br>B7/2H   A193 Gr.B7/A194 Gr. 2H<br>B8   A193 Gr.B8/a194 Gr.8<br>B8M   A193 Gr.B8M/A194 Gr.8M<br>Other   Please Specify (Refer Table 4) |
| <b>Code</b> <b>Carrier Ring Material</b><br>A105   ASTM A105<br>F304   A182 Gr.F304<br>F316   A182 Gr.F316<br>F316   A182 Gr.F316L<br>Other   Please Specify [refer Fe410 CR# Series] | <b>Code</b> <b>End Flange Material</b><br>A105   ASTM A105<br>F304   A182 Gr.F304<br>F316   A182 Gr.F316<br>F316L   A182 Gr.F316L<br>Other   Please Specify                       |
| <b>Code</b> <b>End Connection</b><br>BW   Butt Weld<br>FL   Flanged<br>TH   Threaded<br>ST   Stub End   | <b>Code</b> <b>End Flange Facing</b><br>RF   Raised Face<br>RTJ   Ring Type Join  |
| <b>Code</b> <b>Meter Tube Material</b><br>A106   A106 Gr.B<br>TP304   A312 TP304<br>Tp316   A312 Tp316  | <b>Code</b> <b>End Flange Type</b><br>WN   Weld Neck<br>SO   Slip On<br>SW   Socket Weld<br>T   Threaded<br>LJ   Lap Joint  |

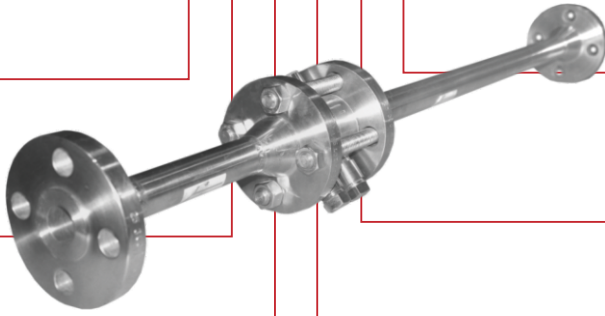

## ORDERING INFORMATION

FE510 CR# Series SEC-316-W1-40NB 300# Sch.80-F316-FL-TP316-WN-RF-F316-GB7/2H-FR-GP-Op1

Hydropneumatics Private Limited

📍 D2-6, B.I.E, Bicholim - Goa 403529 India. ☎ +91-832-236-0364. 📞 +91-932-521-1941

✉ [admin@hydropneumatics.co.in](mailto:admin@hydropneumatics.co.in) 🌐 [www.hydropneumatics.co.in](http://www.hydropneumatics.co.in)