

FN400 W# Series Long Radius Flow Nozzle - Welded

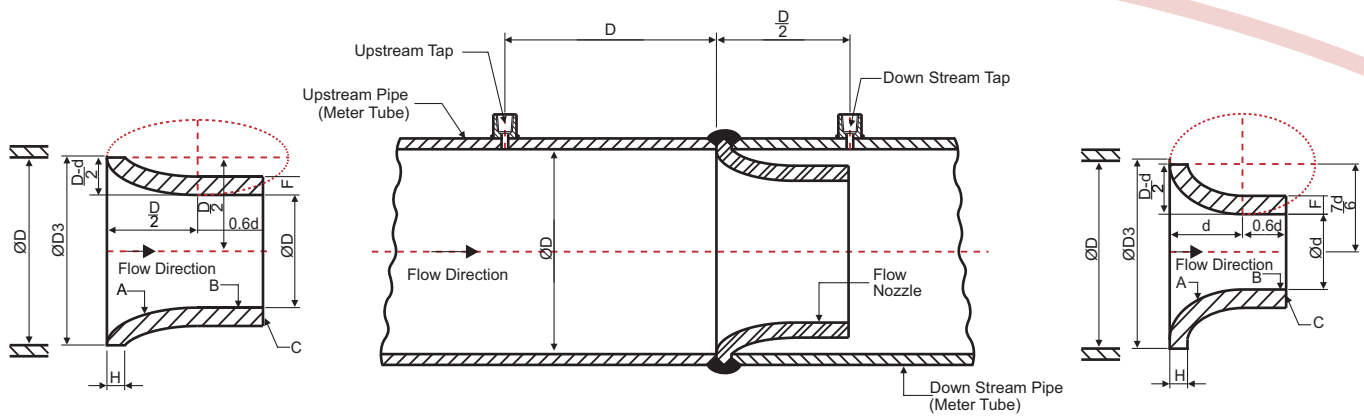

a) LONG RADIUS FLOW NOZZLES - High Beta Ratio $0.25 \geq \beta \geq 0.8$
DESIGN STANDARD
 ISO 5167 / ASME MFC 3M

- A - Convergent Section; (quarter Of An Ellipse)
- B - Throat; Cylindrical Section
- C - Outlet Face
- $\varnothing d$ - Throat Diameter
- $\varnothing D$ - Pipe Internal Diameter
- $\varnothing D3$ - Nozzle Outer Diameter
- β - Beta Ratio = D/d

b) LONG RADIUS FLOW NOZZLES - Low Beta Ratio $0.20 \geq \beta \geq 0.5$
DESIGN STANDARD
 ISO 5167 / ASME MFC 3M

This type nozzle has a machined tongue around its greatest diameter designed to fit between end of both an inlet and outlet pipe section. The pipe sections, with the nozzle in place, are firmly clamped and/or tack-welded in alignment before the finish weld is applied

The Flow Nozzle is used where flanges are not applicable such as high temperature and pressure applications in power plant installations, feed water etc. .The weld-in nozzle is available with complete flow sections.

Code	Element Type
FNLH	Long Radius Flow Nozzle-High Beta
FNLL	Long Radius Flow Nozzle-Low Beta

Code	Element Material
F304/L	A182 Gr.F304 / F304L
F316/L	A182 Gr.F316 / F316L
F11	A182 Gr.F11
F12	A182 Gr.F12
Mo	Monel
Other	Please Specify

Code	Companion Flange Details
XX	Define eg:150NB 600#Sch.120WNRF

Code	Carrier Ring Material
A105	ASTM A105
304/L	A182 Gr.F304/F304L
316/L	A182 Gr.F316/F316L
F5	A182 Gr.F5
F11	A182 Gr.F11
F12	A182 Gr.F12
Other	Please Specify

Code	Companion Flange Details
XX	A193 Gr.B7 / A194 Gr.2H Other [See table - 4]

Code	Option
0	None
1	IBR Form IIIC
2	PWHT
3	Radiography
Other	See Table-7

Code	End Flange Type
XX	Please Define e.g. 150NB 600# Sch.120 WNRF

Code	End Connection
BW	Butt Weld
FL	Flanged

Code	Metrer Tube Length
XX	Please Define e.g. 10D, 15D

Code	Pressure Tapping Connection
3N	1/2" NPT [F]
4N	3/4" NPT [F]
1B	1/2" BSP [F]
2B	3/4" BSP [F]
1T	Other [see table - 6]

ORDERING INFORMATION

FN400 W# Series FNLH-F304-150NB S120-P11-10D-3N-FL-WNRF300# - Op1

Hydropneumatics Private Limited